

Elements of Art Design Compositions

4th June 2005

Computer Graphics & Design 1

Faculty of Information and Communication Technology
Silpakorn University, Thailand

Dr.Surapong Lertsithichai, Ph.D.
Faculty of Architecture, Silpakorn University

Pongpan Suriyapat
IT University of Göteborg, Sweden

What is Design ?

Design could be viewed as an activity that translates an idea into a blueprint for something useful, whether it's a car, a building, a graphic, a service or a process. The important part is the translation of the idea, though design's ability to spark the idea in the first.

The Design Council, UK

- Definitions: Psychology, Art, Engineering, Computer science, etc.
- To imagine and plan out in the mind; to develop for a certain purpose or use
- Design and Art

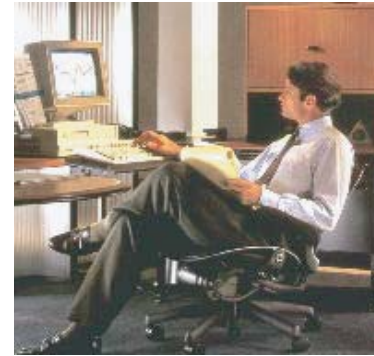
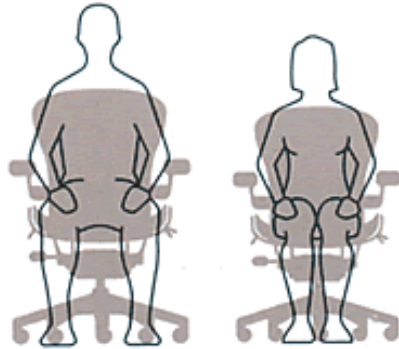

A screenshot of the Endurance FA World Championship website. The page features a red background and includes sections for a 2003 calendar, latest news, and race dates. The calendar lists events for May, June, and July. The news section includes articles about Tomco, Sago, and other drivers. The website also features logos for sponsors like octagon, SBK, and MCN.

Art Form

- Fine Arts

Visual Arts (sculpture, paintings, graphics, crafts)

Audio Arts (music, literature)

Audio/ Visual Arts (drama, film, television)

- Applied Arts

Architecture

Landscape Architecture

City Planning

Interior Architecture

Industrial Design (ceramics, textile, graphic design)

Digital Art / Computer Art / New Media

- Animation, Special Effects

- Game Design

- Interactive Media



**Art + Technology + Collaborative Working
Team Working + Interdisciplinary**

Design Elements

- **Conceptual Elements**

Dot (1D)
Line (2D)
Plane (2D)
Volume (3D)

- **Visual Elements**

Shape
Size
Color
Texture

- **Relational Elements**

Direction
Position
Space
Frame
Gravity

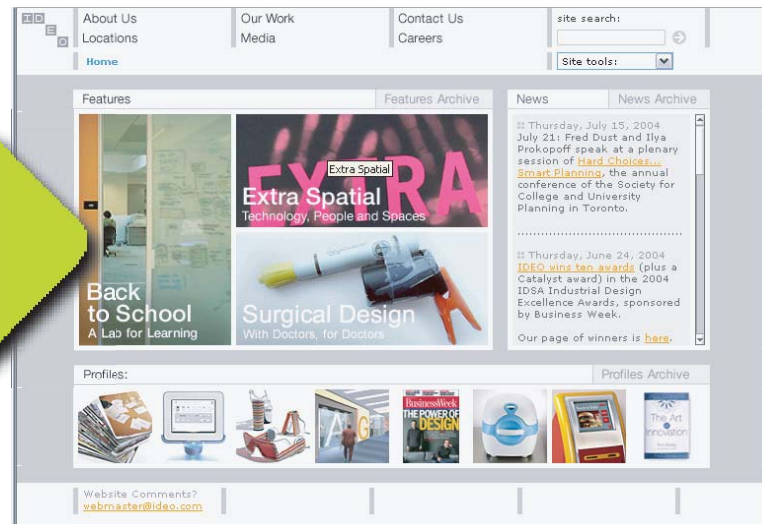
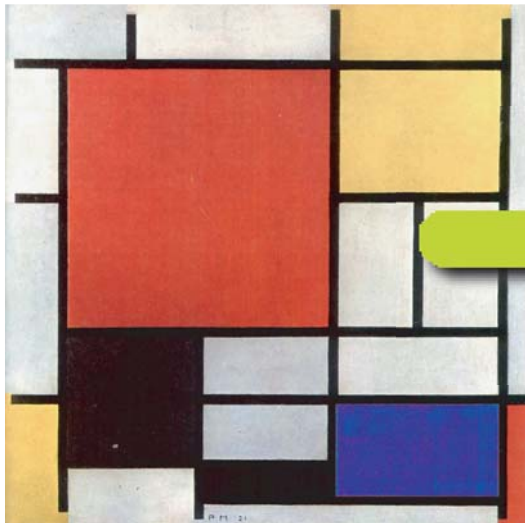

Conceptual Elements

Dot	(0D)
Line	(1D)
Plane	(2D)
Volume	(3D)

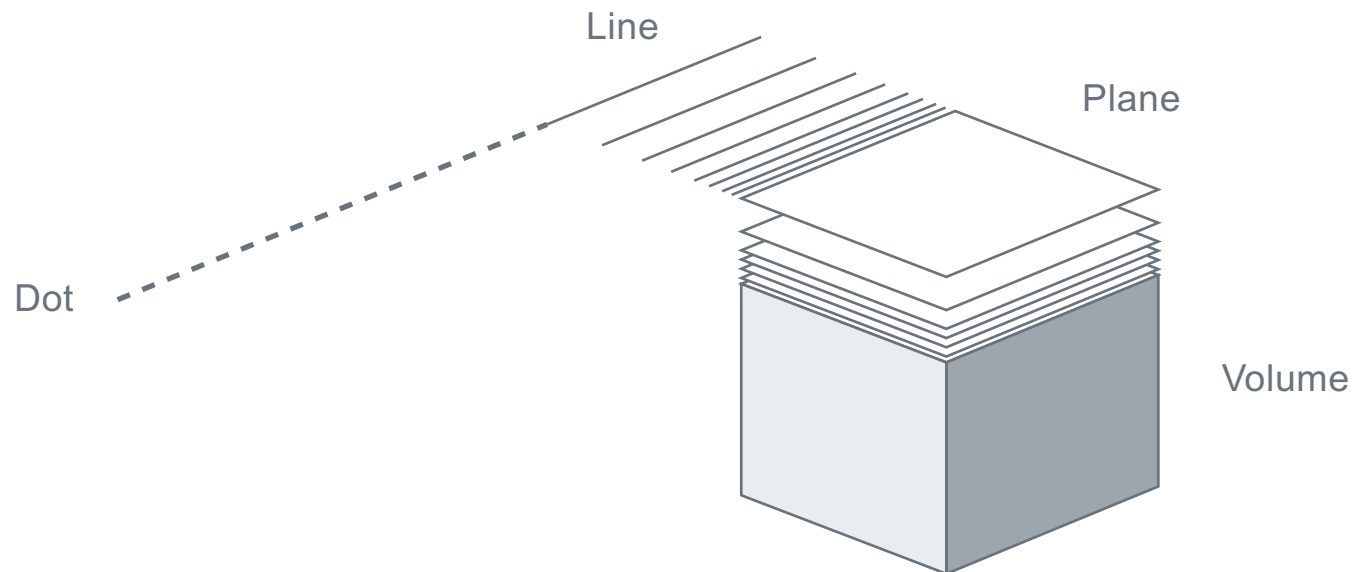

Dots

Shape Size Position Space Direction



Shape

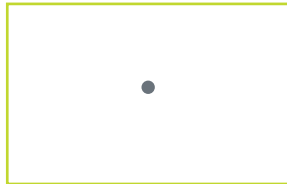
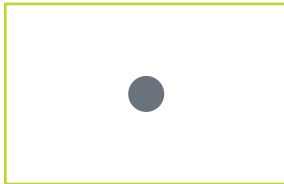

Size

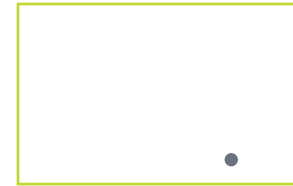
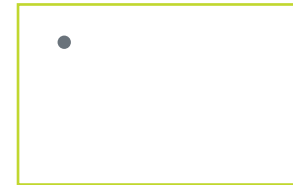
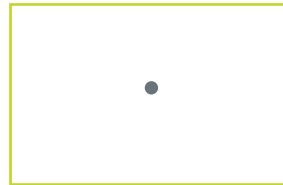

Position

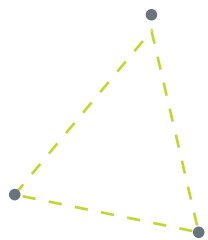
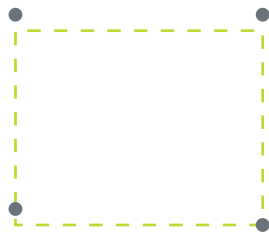

Space



Direction

Lines

Shape Direction Continuity

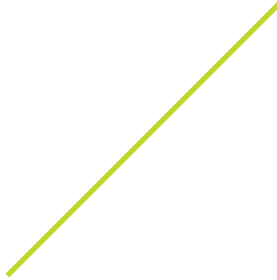

Planes

Geometric Organic Rectilinear Irregular Hand drawn Accidental

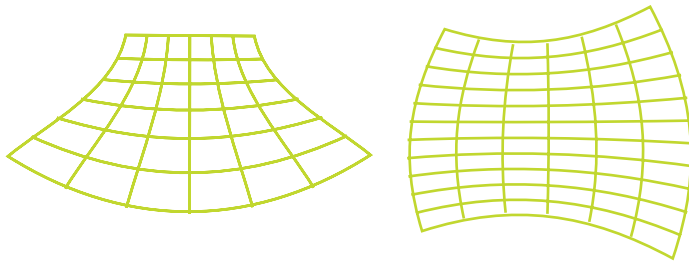

Volume

Shapes Modifications Relationships

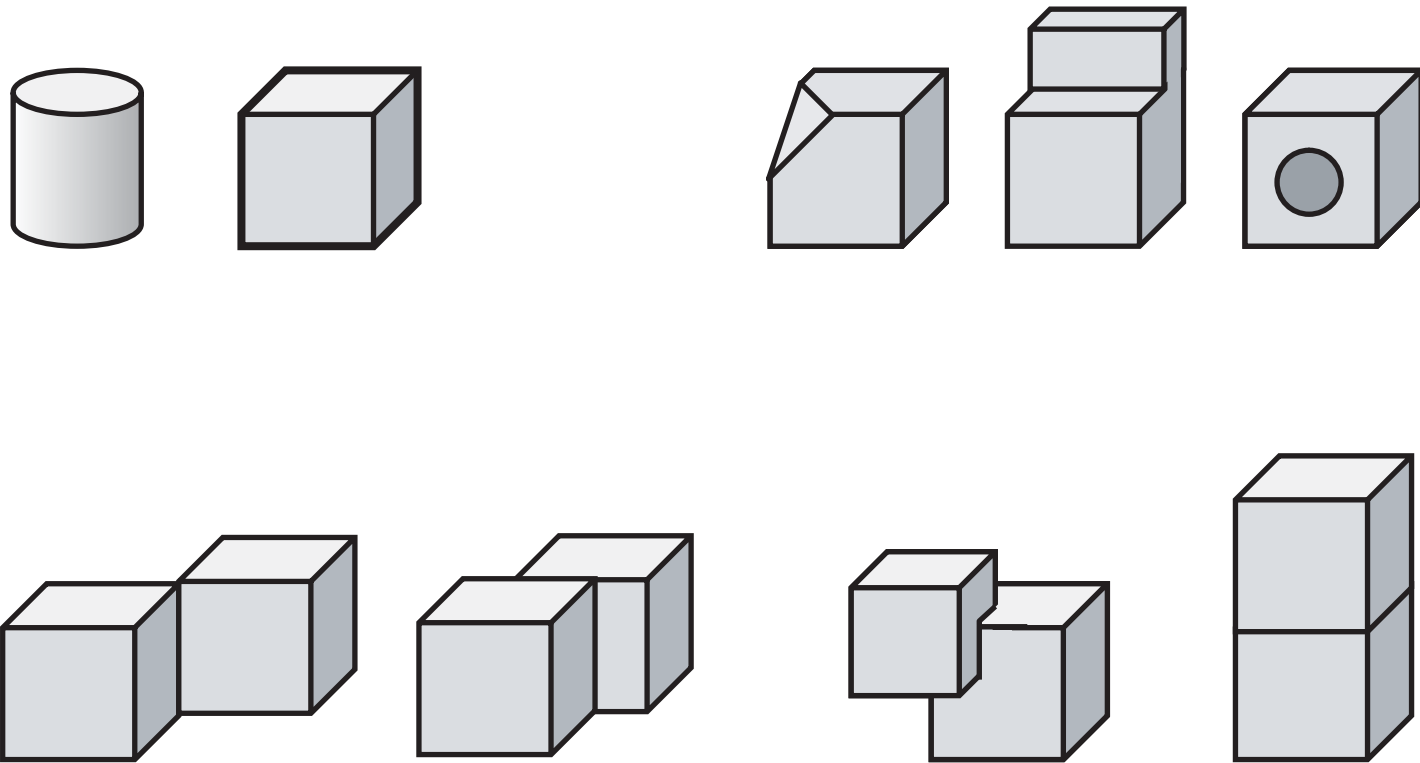

Visual Elements

Shape
Size
Color
Texture

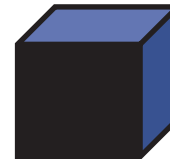
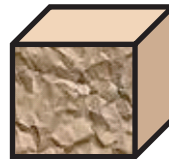
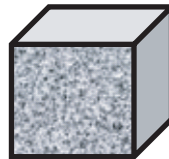
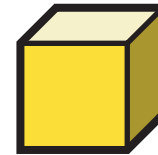
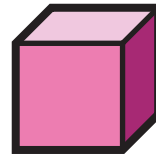
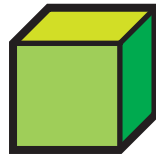
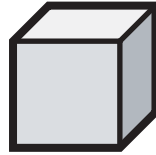
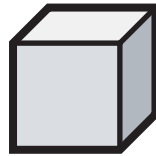

Relational Elements

Direction
Position
Space
Frame
Gravity

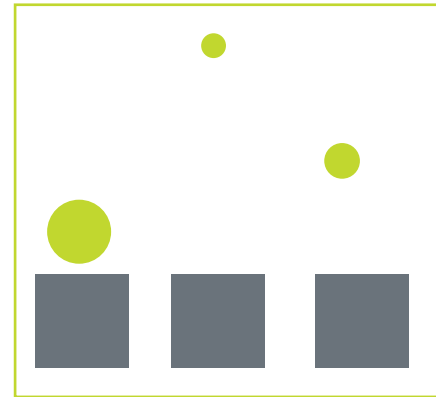
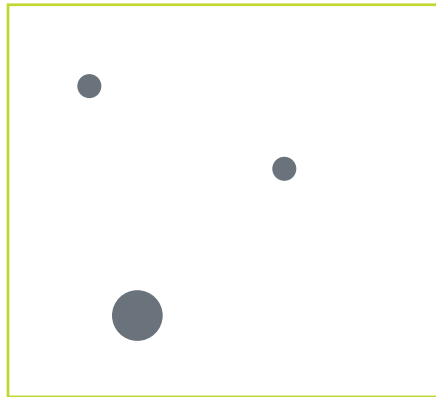
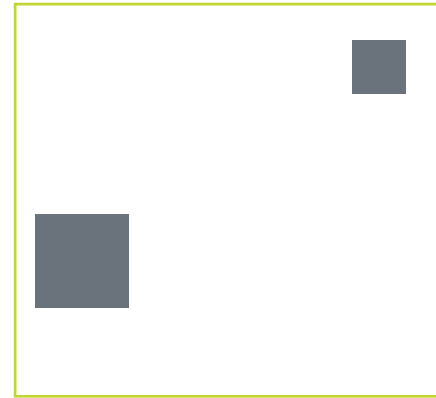

Design Compositions

Unity

Proximity
Repetition
Continuation
Variety

Emphasis

Focal Point
Contrast
Isolation
Placement

Techniques

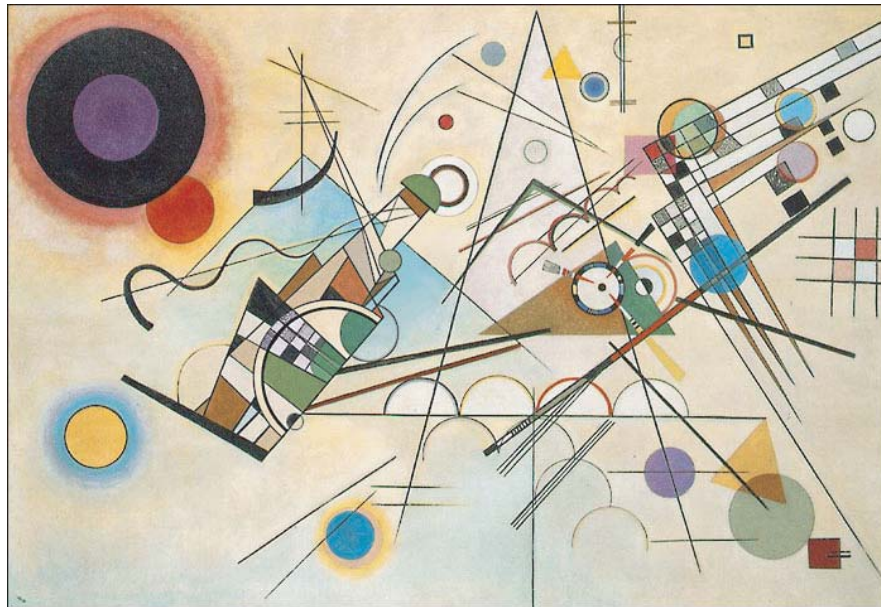

Unity

Proximity
Repetition
Continuation
Variety

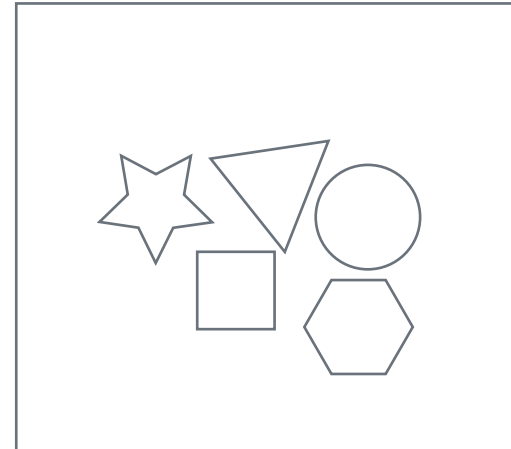
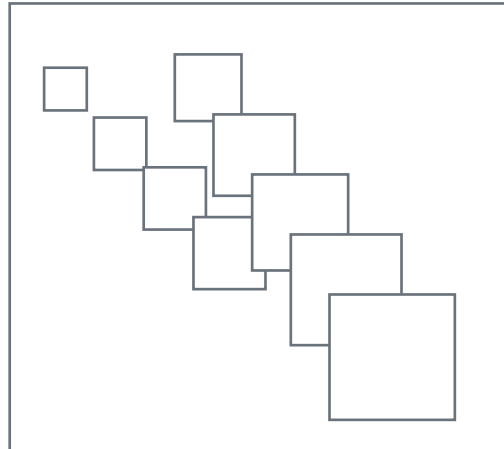
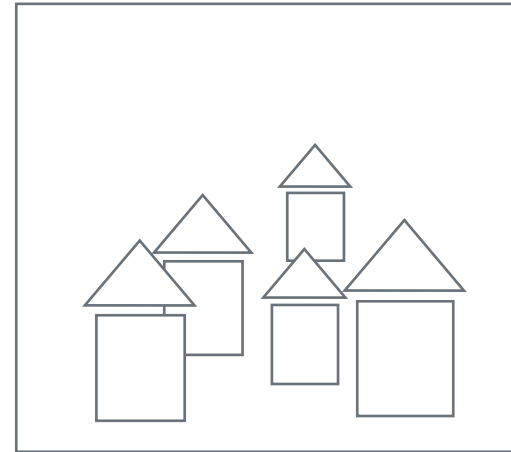
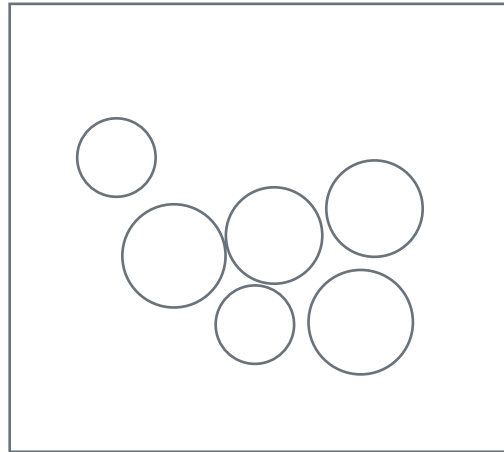

Emphasis

Focal Point
Contrast
Isolation
Placement

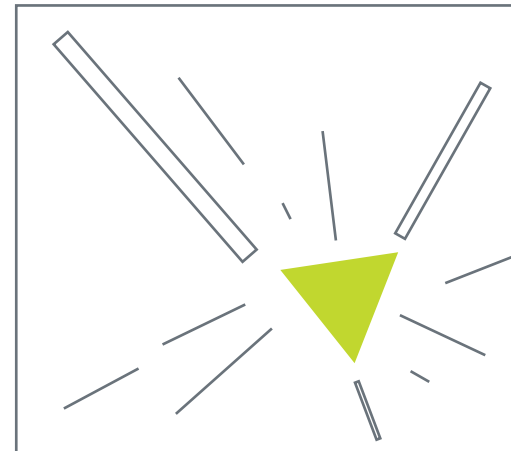
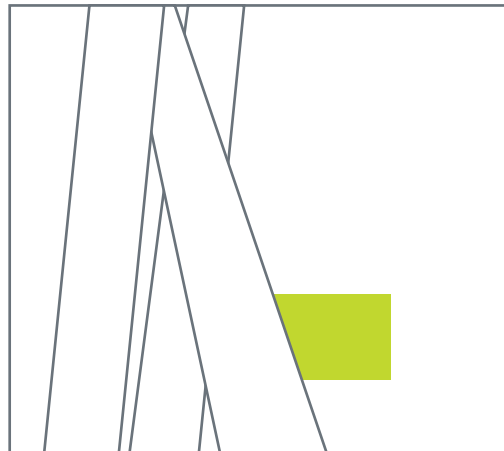
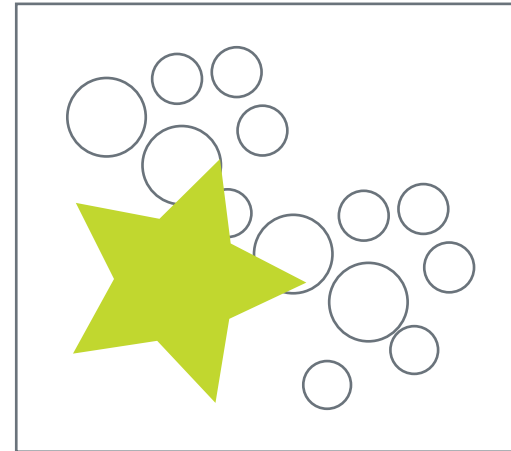
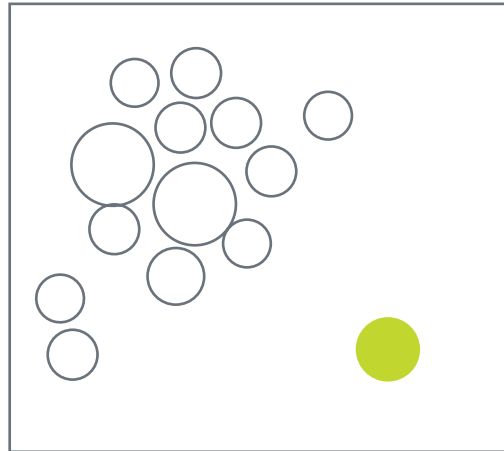

Studio Work 1

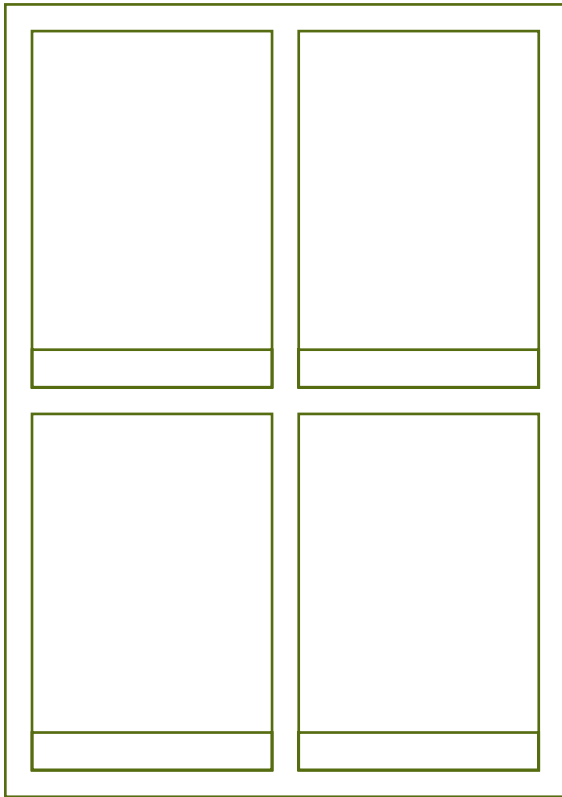

Unity

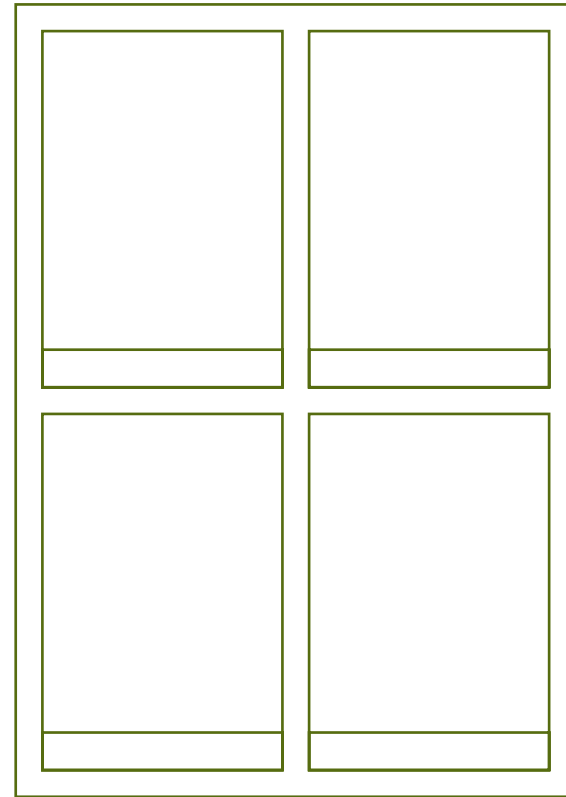

Emphasis

Home Work 1

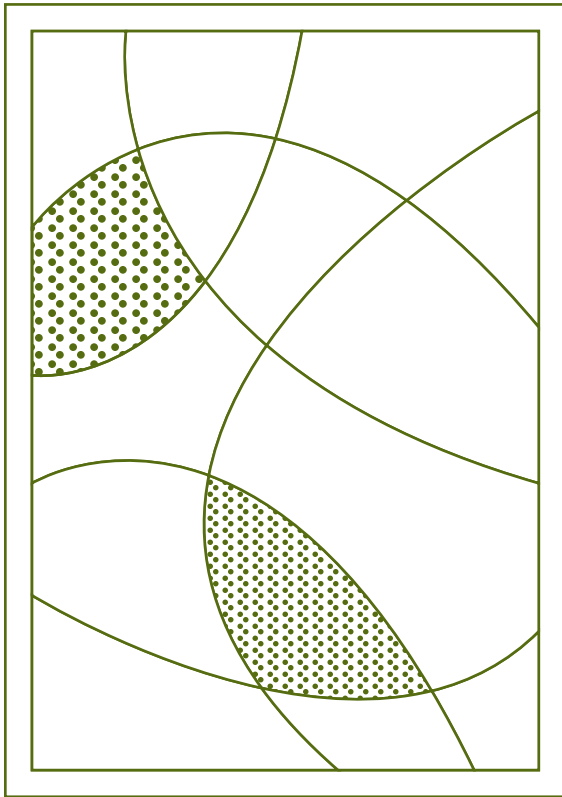

Dot

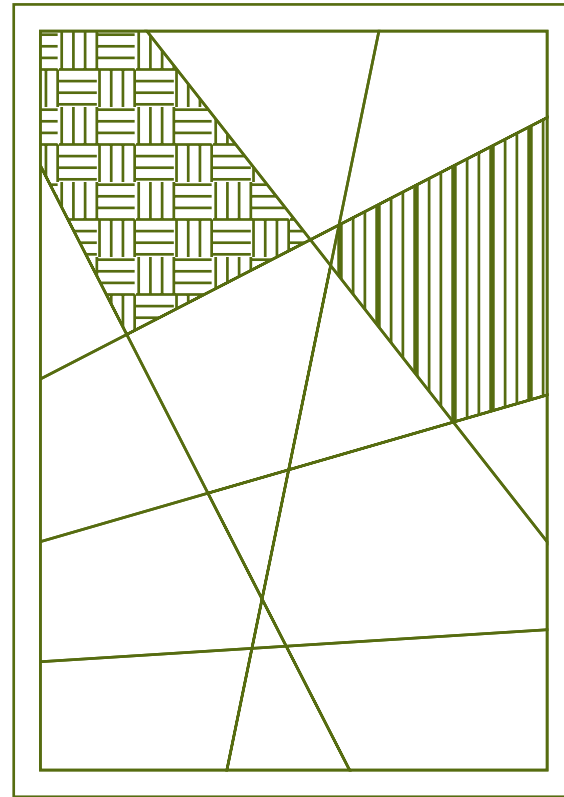

Line